



## SOLAER® SB1 AND SB2 PATENTED SOLAR AERATION SYSTEM

The Keeton Industries Solaer series of solar powered lake bed aeration systems are the ideal choice for remote ponds and lakes where power is not available or for an environmentally conscious solution. The SB-1 and SB-2 are effective in aerating ponds and lakes up to 2 surface acres in size. These systems come complete with a high efficiency solar panel, charge control system, battery back-up, EcoFlow energy efficient compressor, high volume cooling fans, programmable digital timer and a fully adjustable aluminum manifold housed in attractive, 100% recycled plastic cabinet. Duraplate self-cleaning, non-clogging membrane diffusers emit millions of tiny bubbles that increase dissolved oxygen levels while eliminating stratification, improving water quality and clarity.



Shown with Level-aer Equipment Pad – additional upgrade.

### The Cabinet

- 100% recycled plastic cabinet
- 20"W x 24"L x 27" T
- 37cfm cooling blower
- Two - 2 Valve Adjustable Manifolds
- Programmable Digital Timer
- Sound reduction package
- 1" ASTM certified Acoustical Foam
- Charge Control System
- Dual EcoFlow 24V Compressors
- 24 V High Efficiency Solar Panel



### The Tubing

- Self-weighted
- 1/2" I.D. with 1/4" sidewalls
- Fishhook resistant
- Will not kink or break
- Available in 100' and 500' lengths
- 15 year warranty



### The Diffuser

- Self-cleaning
- Non-clogging
- Self-weighted
- Fishhook resistant
- High Oxygen transfer
- Lifetime warranty

Model	Features
SB-1	1 Diffuser
SB-1B	1 Diffuser & 100' of Tubing
SB-2	2 Diffusers
SB-2B	2 Diffusers & 200' of Tubing



OTHER PONDS AND LAKES ARE GREEN WITH ENVY®

keetonaquatics.com | 800.493.4831 | 970.568.7754



**SOLAER® SB1 AND SB2**  
**PATENTED SOLAR AERATION SYSTEM**

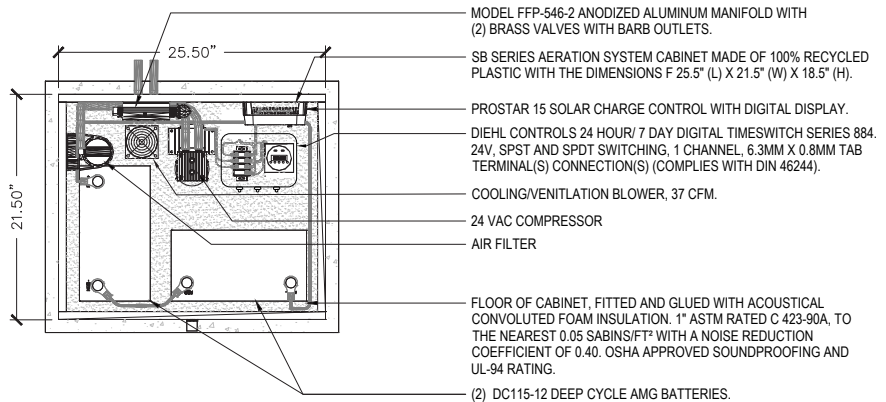
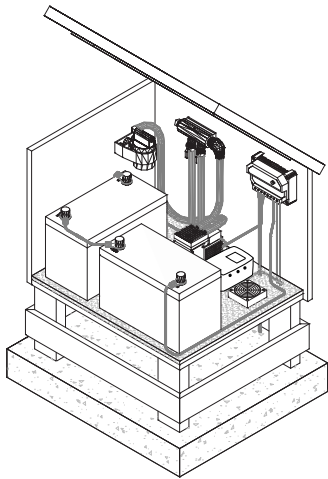

**TOP VIEW (SEE SHEET #2)**

NOT TO SCALE

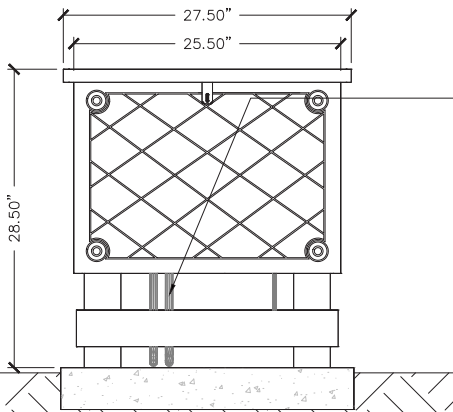

**FRONT VIEW**

NOT TO SCALE

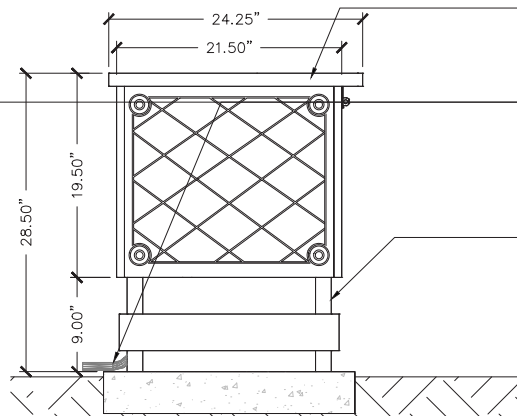

**SIDE VIEW**

NOT TO SCALE



**TITLE:**  
**SOLAER AERATION SYSTEM**  
**SB 1-2 SERIES - MULTI VIEW**

<b>DATE:</b> 1/17/2012	<b>SHEET:</b> 1
---------------------------	--------------------



OTHER PONDS AND LAKES ARE GREEN WITH ENVY®

keetonaquatics.com | 800.493.4831 | 970.568.7754