



Why choose the Robust-Aire Aquatic Aeration System?

Robust-Aire is the result of years of coordinated research and development at Kasco Aeration, an organization dedicated to producing efficient, high-quality water management equipment for over 40 years.

Superior Efficiency

Kasco Aeration uses superior diffuser materials and design. Robust-Aire has been tested alongside 6 other leading designs by 4 other manufacturers. Between 10 and 44% more water flow was induced with the same volume of air injected into the water column. The system simply creates more water flow to aerate the pond with the same amount of air and energy making it **the most efficient** on the market.

This is the result of an efficient diffuser which allows air to escape at a very low pressure, to produce smaller bubbles with less friction loss. The bubbles are approximately 3mm in diameter. The U-shaped design and placement of the four diffusers enhances the upward flow of water.

The diffuser material is durable and cleanable. While nothing is maintenance free, seasonal cleaning of the diffusers in order to maintain efficiency is easy. The hydrophobic material partially repels growth films and can be cleaned with a rag or gloved hand.

Design

Our diffuser assembly is compact, and comes fully assembled in one UPS shippable box.

The base is made of recycled HDPE and has sturdy thick walls. The ergonomic design has *hand holds*, a large *fill port* to add gravel, and a locking, vented fill plug. A sturdy *strain relief* is provided to hold the weighted tubing firmly in place with the base unit. This keeps the strain off the barb fitting where air is delivered into the diffuser assembly. A *check valve* is located on the incoming port with a Viton seal that cracks open at only 1/3 PSI of pressure. A Hastelloy (known as super-stainless) spring is used internally that will not corrode.

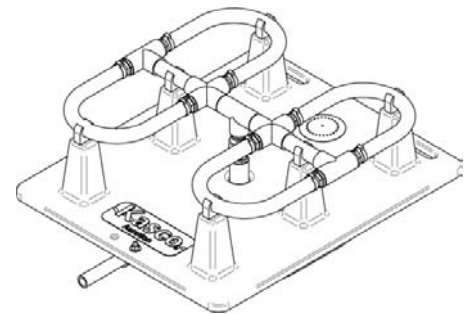

Sure Sink tubing

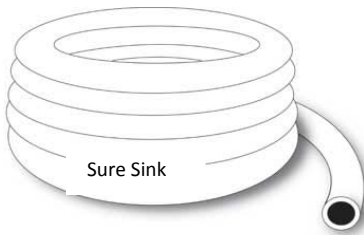

Sure Sink self-weighted tubing is a durable PVC composite available in both 3/8 and 5/8 inch. The hose will not crack during cold weather and will remain flexible. The 3/8 tubing is used for lengths below 300 feet and is offered to save on purchase price, installation effort, as well as shipping & handling costs. Marks are placed every foot on all weighted tubing to assist with measurements in the field. Non-weighted tubing is available for direct burial for installations where a significant distance is between the compressor location and the water's edge.

Complete

The Robust-Aire System comes complete. We included both 3/8 and 5/8 components, including adapters in every box of tubing and in every diffuser assembly.

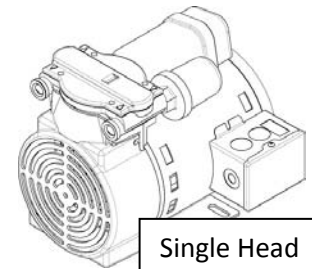

Single Head

Rocking Piston Compressors

The Robust-Aire systems use a rocking piston compressor for the ability to address deeper water applications, and to reduce maintenance. Capable of injecting air to 50 feet of depth, these rugged compressors provide many years of dependable service.

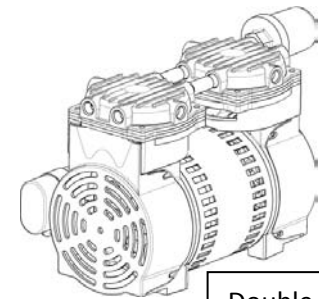

Double Head

Installation and cabinet options.

Robust-Aire is available *without a cabinet* and with two options for housing in high quality metal cabinets with forced ventilation. The Robust-Aire NC model has no cabinet and may be conveniently housed at your covered and ventilated location. The *standard cabinet option* is floor/ground mounted cabinet. The galvanized steel cabinet has beige colored powder coating, and internal electrical junctions to pair each compressor with a ventilation fan providing 110 CFM of cooling air across the motor. This cabinet can house 2 compressors, offering systems with up to 6 diffuser stations.

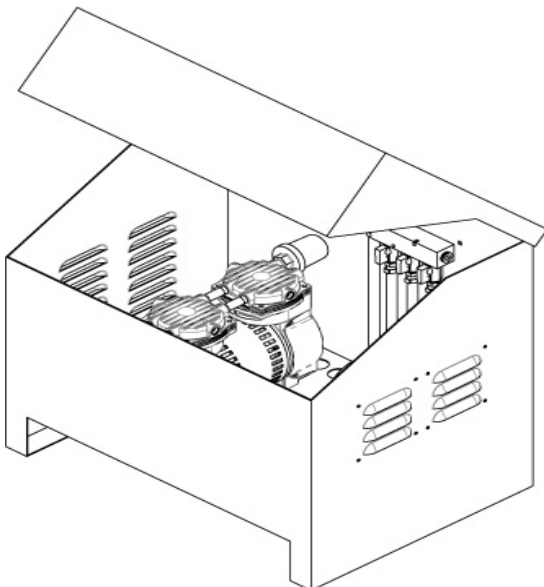

The *post mounted cabinet* houses one compressor and can provide air supply for up to 3 diffuser stations. About the size of a large mailbox, this beige colored, powder coated, aluminum cabinet can be mounted on a wall or single 4 x 4 wooden post. Over 16 square inches of ventilation and a single 110 CFM are included in this compact design. full length “piano style” hinge allows for full access to internal components for inspection and maintenance.

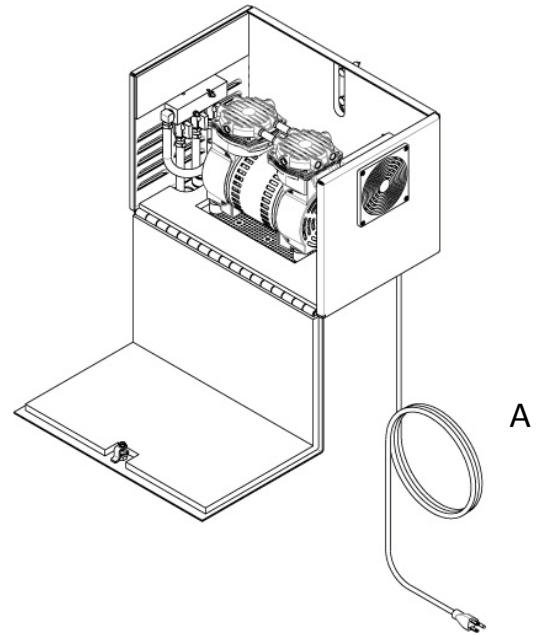

All systems with more than one diffuser use an *aluminum block manifold with compact valves* to divide air flow and control supply to each diffuser station. This is important to deliver air equally even though diffusers may be operating under different pressures due to the length of tubing and depth of the diffuser station. The compact design allows for more convenient assembly and maintenance.

Robust-Aire cabinet models are fully assembled at the factory with compressors, fans, manifolds, installed, and leads ready for tubing to be attached.

Expert Design assistance

Design assistance is available by biologists and engineers at Kasco Aeration to assure your project goals are achieved. Provide an internet searchable address or a sketch and measurements of your pond or lake and the Kasco team will provide customized planning to design a system that will accommodate your desired turnover rate.

Superior performance, thoughtful design, and professional assistance from an industry leader. That is why so many pond owners and water management professionals are choosing Robust-Aire.

Kasco Marine, Inc. 800 Deere Road, Prescott, WI 54021-1241
Phone (715) 262-4488 • Fax (715) 262-4487

www.kascomarine.com • sales@kascomarine.com